

Contribution of Rapid Evolution of the *luxR-luxI* Intergenic Region to the Diverse Bioluminescence Outputs of *Vibrio fischeri* Strains Isolated from Different Environments^{∇†}

Jeffrey L. Bose,¹ Michael S. Wollenberg,² Deanna M. Colton,¹ Mark J. Mandel,³
Alecia N. Seprer,¹ Anne K. Dunn,^{1,4} and Eric V. Stabb^{1*}

Department of Microbiology, University of Georgia, Athens, Georgia 30602¹; Department of Medical Microbiology and Immunology, University of Wisconsin, Madison, Wisconsin 53706²; Department of Microbiology-Immunology, Northwestern University, Chicago, Illinois 60611³; and Department of Botany and Microbiology, University of Oklahoma, Norman, Oklahoma 73019⁴

Received 11 November 2010/Accepted 2 February 2011

Vibrio fischeri serves as a valuable model of bacterial bioluminescence, its regulation, and its functional significance. Light output varies more than 10,000-fold in wild-type isolates from different environments, yet dim and bright strains have similar organization of the light-producing *lux* genes, with the activator-encoding *luxR* divergently transcribed from *luxICDABEG*. By comparing the genomes of bright strain MJ11 and the dimmer ES114, we found that the *lux* region has diverged more than most shared orthologs, including those flanking *lux*. Divergence was particularly high in the intergenic sequence between *luxR* and *luxI*. Analysis of the intergenic *lux* region from 18 *V. fischeri* strains revealed that, with one exception, sequence divergence essentially mirrored strain phylogeny but with relatively high substitution rates. The bases conserved among intergenic *luxR-luxI* sequences included binding sites for known regulators, such as LuxR and ArcA, and bases of unknown significance, including a striking palindromic repeat. By using this collection of diverse *luxR-luxI* regions, we found that expression of $P_{luxI-lacZ}$ but not $P_{luxR-lacZ}$ transcriptional reporters correlated with the luminescence output of the strains from which the promoters originated. We also found that exchange of a small stretch of the *luxI-luxR* intergenic region between two strains largely reversed their relative brightness. Our results show that the *luxR-luxI* intergenic region contributes significantly to the variable luminescence output among *V. fischeri* strains isolated from different environments, although other elements of strain backgrounds also contribute. Moreover, the *lux* system appears to have evolved relatively rapidly, suggesting unknown environment-specific selective pressures.

Bioluminescence is widespread within the *Vibrionaceae*; however, the selective pressures driving its evolution are not always clear (62). Further adding to the mystery of bacterial bioluminescence, light output can vary over orders of magnitude between different environmental isolates. For example, obvious visible luminescence has been frequently associated with a number of species, such as *Vibrio fischeri*, *Vibrio harveyi*, *Photobacterium leiognathi*, and *Photobacterium phosphoreum*; however, dim and even “cryptic” luminescence has also been observed upon careful examination of certain isolates, such as *Vibrio salmonicida* (20). Even isolates of the same species can vary in luminescence output (23, 49). Such variation is dramatically evident in *V. fischeri* (5, 32, 45, 62), which is a longstanding model for studying bioluminescence, its functional roles, and its regulation.

Bioluminescence in *V. fischeri* is directed by the *lux* genes. The genes responsible for bioluminescence, *luxABCDE* and *luxG* are clustered with the regulatory genes *luxR* and *luxI* and are arranged in two divergent transcripts composed of *luxR* and *luxICDABEG* (17, 18, 22, 41). The regulatory genes, *luxI*

and *luxR*, constitute a pheromone-mediated regulatory mechanism referred to as quorum sensing. LuxI produces a membrane-permeable autoinducer pheromone, *N*-3-oxohexanoyl-L-homoserine lactone (3-oxo-C6-HSL) (15, 29). As cell density increases, 3-oxo-C6-HSL accumulates until achieving a threshold concentration, whereupon it combines with LuxR to activate transcription of *luxICDABEG* (17, 18, 72). *V. fischeri* generates two additional autoinducers, *N*-octanoyl-L-homoserine lactone (C8-HSL) and autoinducer 2 (AI-2), which are produced by AinS and LuxS, respectively. C8-HSL and AI-2 regulate luminescence in part through a pathway involving LuxU, LuxO, and LitR, resulting in increased LuxR at high cell density (19, 35–37, 43). We previously reviewed the interplay of these regulatory systems (68). Ultimately, all three autoinducers affect transcription from the intergenic *luxR-luxI* region.

For reasons that are not well understood, the brightness of different wild-type *V. fischeri* strains can vary greatly (5, 45). For example, a comparison of strains MJ1 (57) and ES114 demonstrated that MJ1 has ~10,000-fold-higher luminescence (5, 8). Moreover, saturating ES114 with exogenously added autoinducer does not increase the luminescence of ES114 to the levels of MJ1, and ES114 produces little endogenous 3-oxo-C6-HSL autoinducer, even when *luxI* is induced fully by exogenously added autoinducer (22). These data demonstrate that different strains not only produce varied levels of luminescence but also may have different maximal capacities for *luxICDABEG* expression.

* Corresponding author. Mailing address: University of Georgia, Department of Microbiology, 1000 Cedar Street, Athens, GA 30602. Phone: (706) 542-2414. Fax: (706) 542-2674. E-mail: estabb@uga.edu.

† Supplemental material for this article may be found at <http://aem.asm.org/>.

∇ Published ahead of print on 11 February 2011.

TABLE 1. Wild-type *V. fischeri* strains and select corresponding plasmids used in this study

Strain	Species or description	Source or reference	Luminescence class ^a	Intergenic <i>lux</i> clone ^b	$P_{luxR-lacZ}$ reporter ^c	$P_{luxI-lacZ}$ reporter ^c
CG101	<i>Cleidopus gloriamaris</i>	56	HV	pJLB156	pJLB180	pJLB181
CG103	<i>Cleidopus gloriamaris</i>	31	HV	pJLB26	pJLB180	pJLB181
EM17	<i>Euprymna morsei</i>	56	V	pJLB165	pJLB196	pJLB197
ES114	<i>Euprymna scolopes</i>	5	NV	pJLB29	pJLB170	pJLB171
ES12	<i>Euprymna scolopes</i>	6	NV	pJLB161	pJLB188	pJLB189
ES213	<i>Euprymna scolopes</i>	6	NV	pJLB166	pJLB188	pJLB189
ES401	<i>Euprymna scolopes</i>	56	NV	pJLB167	pJLB198	pJLB199
ET101	<i>Euprymna tasmanica</i>	48	V	pJLB163	pJLB192	pJLB193
ET401	<i>Euprymna tasmanica</i>	47	V	pJLB164	pJLB194	pJLB195
H905	Hawaii, planktonic	33	V	pJLB168	pJLB200	pJLB201
MJ1S ^d	<i>Monocentris japonica</i>	Lab collection	HV	pJLB30	pJLB172	pJLB173
MJ1	<i>Monocentris japonica</i>	E. P. Greenberg	HV	pJLB79	pJLB204	pJLB205
MJ11	<i>Monocentris japonica</i>	56	HV	pJLB157	pJLB172	pJLB173
PP3	Hawaii, planktonic	33	V	pJLB25	pJLB202	pJLB203
SA1	<i>Sepioloa affinis</i>	21	HV	pJLB159	pJLB184	pJLB185
SR5	<i>Sepioloa robusta</i>	21	HV	pJLB162	pJLB190	pJLB191
VLS2	<i>Euprymna scolopes</i>	31	V	pJLB158	pJLB182	pJLB183
WH1	Massachusetts, planktonic	31	HV	pJLB160	pJLB186	pJLB187
Mutant strains						
JB3	ES114; intergenic <i>lux</i> element from MJ1S	This study	V	NA ^e	pJLB174	pJLB175
JB7	MJ1S; intergenic <i>lux</i> element from ES114	This study	V	NA	pJLB176	pJLB177

^a Strains were designated as producing nonvisible (NV), visible (V), or highly visible (HV) luminescence on SWTO plates.

^b *lux* intergenic regions were cloned in pCR-Blunt or pCR-BluntII-TOPO (see Materials and Methods).

^c Some strains had identical *luxR-luxI* intergenic sequences, and only one P_{luxR} - and P_{luxI} -*lacZ* reporter plasmid was made for each unique sequence; therefore, some reporter plasmids represent more than one strain (including CG101 and CG103, MJ1S and MJ11, and ES12 and ES213).

^d Strain MJ1S was previously published by our laboratory as MJ1 (7, 8, 60, 64).

^e NA, not applicable (see Materials and Methods).

The evolution of such varied luminescence output and the underlying reason for the phenomenon are not well understood. There are several plausible explanations for the variable *luxICDABEG* expression among strains from different environments, and the mechanism(s) underpinning this variation could involve one or multiple Lux proteins, regulatory sequences at the *luxI* or *luxR* promoters, other elements of the strain background, or a combination of factors.

To explore these possibilities, and in particular to investigate the contributions of the *lux* locus, we systematically compared the light output, *lux* sequences, and other gene sequences from strains with different luminescence capacities. Our results suggest that the *luxR-luxI* intergenic region has been evolving rapidly and contributes significantly to the variable luminescence output among *V. fischeri* strains, although other elements of strain background contribute as well.

MATERIALS AND METHODS

Strains and media. *V. fischeri* strains used in this study are listed in Table 1. *Escherichia coli* strains DH5 α (24) and DH5 α pir (13) were used for cloning, with the latter being employed with plasmids bearing the R6K γ origin of replication, including pAKD702 and its derivatives. *E. coli* CC118 Δ pir (26) carrying helper plasmid pEVS104 (67) was used in triparental matings. *E. coli* was grown in LB medium (42), and *V. fischeri* was grown in LBS (66) or SWTO (7) medium. Agar at 15 mg ml⁻¹ was added to solidify medium for plating. Chloramphenicol, kanamycin, and ampicillin were added at 20, 40, and 100 μ g ml⁻¹, respectively, for selection of *E. coli* on LB. Chloramphenicol was added to LBS at 2 μ g ml⁻¹ for selection of *V. fischeri*.

OD₅₉₅ and luminescence measurements. For measurements of growth and luminescence, overnight cultures grown in LBS were diluted 1:500 in SWTO, incubated at 24°C with shaking (200 rpm), and monitored as described previously (7, 8). Briefly, 500- μ l samples were taken at regular intervals, and the optical density at 595 nm (OD₅₉₅) was determined with a BioPhotometer (Brinkmann Instruments, Westbury, NY). Relative luminescence was determined using a

TD-20/20 or TD-20/20n luminometer (Turner Designs, Sunnyvale, CA), immediately after vigorous shaking to oxygenate the sample. The term relative luminescence means that the units are arbitrary but that values can be used to compare samples relative to one another. The specific luminescence (relative luminescence per OD₅₉₅) reported was measured for whole cells. As previously reported, even with a bright strain there is no indication that luminescence becomes oxygen limited or otherwise decays over the course of these measurements (8).

Luminescence on solid medium was also examined qualitatively and quantitatively. Colonies were scored blind as either producing nonvisible, visible, or highly visible luminescence, based on the consensus of multiple observers (Table 1). For quantitative measurements, colonies of each strain were patched in triplicate onto SWTO plates and incubated at 24°C for 18 h. Patches were resuspended separately in Instant Ocean (Aquarium Systems, Mentor, OH), and the OD₅₉₅ and luminescence were measured for each suspension as described above.

Molecular genetic techniques. Cloning was performed using standard techniques. Plasmids were purified using Qiagen miniprep kits (Valencia, CA). PCR products were cloned into pCR-Blunt or pCR-BluntII-TOPO using the corresponding kit from Invitrogen (Carlsbad, CA). Oligonucleotides (Table 2) were synthesized by Integrated DNA Technologies (Coralville, IA). Klenow fragment, DNA ligase, and restriction enzymes were obtained from New England Biolabs (Beverly, MA). Between restriction and ligation reactions, DNA was recovered with the DNA Clean and Concentrator 5 kit (Zymo Research, Orange, CA). PCR was performed with an iCycler (Bio-Rad Laboratories, Hercules, CA) using KOD DNA polymerase (Novagen, Madison, WI). Sequences were analyzed using Sequencher (Gene Codes Corp., Ann Arbor, MI) and DNA Strider.

The *lux* intergenic regions from the wild-type strains listed in Table 1 were PCR amplified using primers EVS109 and EVS110 (Table 2) and inserted into pCR-Blunt(pJLB25-pJLB30) or pCR-BluntII-TOPO(pJLB79-pJLB168) for sequencing (Table 1). To generate transcriptional reporters that place P_{luxI} or P_{luxR} upstream of *lacZ*, the *AvrII* fragment containing the *luxR-luxI* intergenic region from each plasmid above was cloned into the *NheI* site upstream of a promoterless *lacZ* in pAKD702 (see the supplemental material in reference 7). The resulting reporter plasmids are listed in Table 1. In addition, the *luxR-luxI* intergenic regions from strains JB3 and JB7 (described below) were PCR amplified using primers EVS109 and EVS110, and the resulting products were digested with *AvrII* and cloned into the *NheI* site of pAKD702 to form reporters based on these mutant alleles in pJLB174 to pJLB177 (Table 1). To generate

TABLE 2. Oligonucleotides used in this study

Oligonucleotide	5'–3' sequence ^a	Source or reference
EVS109	CCG <u>CCC TAG</u> GTT ATT CAG ATA AGC ATT GAT TAA TAT C	14
EVS110	CCG <u>CCC TAG</u> GGC ATG CTT AAC CTC TAT ACT CCT CCG ATG GAA	14
EVS129	GTG TTA TCT CTT CAT CGA TAG TGA ATG	This study
EVS130	GAT AAC GGA AGT TTC TAA TCG AGA AGT	This study
JBESMUT1	P-TAA TAA ATT CGA TCT GGG TCA CAT TTA TGC ATC TTG	This study
JBESMUT2	P-GAA TCA AAT ATC ACC AAA CCT CCA AAT TGG TG	This study
JBMJMUT1	P-CAA TTA ATT GGA TTT TTG TCA CAC TAT TGT ATC GC	This study
JBMJMUT2	P-GAA GCG ATG TCA ATC CAT TAC CGT TTT AAT G	This study
katA_2_fw	CGT GGT ATT CCT GCA ACA TAC	39
katA_3_rv	CCG ATA CCT TCA CCA TAA GC	39
katA_whole_fw	TGT CCT GTT GCA CAT AAC C	39
katA_whole_rv	CGC TTA CAT CAA TAT CAA G	39
mdh_1_fw	GGC ATT GGA CAA GCG TTA GC	39
mdh_2_rv	CGC CTC TTA GCG TAT CTA GC	39
mdh_whole_fw	AAG TAG CTG TTA TTG GTG C	39
mdh_whole_rv	CTT CGC CAA TTT TGA TAT CG	39
PconF	TTG ACA TAA AGT CTA ACC TAG GGT ATA ATT CCA TG	This study
PconR	GAA TTA TAC CCT AGG TTA GAC TTT ATG TCA ACA TG	This study
recA610Wolfwd	CTA GNH TTD AWY GSN GCN GC	39
recA610Wolrev	CTT CAC GGT TAA AAC CTT GG	39
recA_whole_fw	GAC GAT AAC AAG AAA AAA GCA CTG G	39
recA_whole_rv	CGT TTT CTT CAA TTT CWG GAG C	39

^a P at the start of a sequence indicates 5' phosphorylation. Underlined regions indicate AvrII sites that are absent in the *lux* template sequence but were incorporated in the primers to facilitate subcloning. Letters that do not correspond to standard bases refer to mixed bases at that position, following the standardized code of the International Union of Biochemistry (e.g., N is A, T, G, or C).

additional reporter controls, a consensus promoter was made by annealing oligonucleotides PconF and PconR together, and this synthetic promoter-containing insert was ligated into NheI-digested pAKD702. The resulting plasmid, in which the consensus promoter drives *lacZ* expression, was named pJLB207, and a plasmid with this insert in the opposite orientation was named pJLB206. Reporter plasmids were mobilized into *V. fischeri* from *E. coli* by triparental mating using pEVS104 as a helper plasmid as previously described (67).

To generate alleles with site-directed changes in the *luxI-luxR* intergenic region, we began with cloned copies of this region from strain ES114 or MJ1S in plasmid pEVS147 or pJLB62, respectively (8). The *luxI-luxR* intergenic region of ES114 was subcloned by placing a SpeI-NheI fragment of pEVS147 into the mobilizable vector pEVS118 (13), generating pEVS150. We next designed primers that would amplify around pEVS150 or pJLB62, while within the primer were sequences that would incorporate targeted sequence alterations. These primers were phosphorylated, so that PCR products could be self-ligated, and generate new plasmids with the desired allelic changes and unaffected flanking regions, traits that were confirmed by sequencing. Primers JBESMUT1 and JBESMUT2 were used with the pEVS150 template, whereas primers JBMJMUT1 and JBMJMUT2 were used with the pJLB62 template; the products were each self-ligated, and the resulting plasmids were designated pJLB58 and pJLB64, respectively. We found that inclusion of a ColE1 replication origin facilitates allelic exchange in *V. fischeri*, and to add this origin to pJLB58, this plasmid was digested with SpeI and fused to SpeI-digested pBluescript KS(+), generating pJLB61.

Chromosomal changes in *V. fischeri* were engineered by allelic exchange. Alleles were mobilized into *V. fischeri* from *E. coli* by triparental mating (67), followed by selection and isolation of strains bearing single crossovers. These strains were then grown and plated nonselectively on LBS and patched onto medium containing an appropriate antibiotic to identify double-crossover mutants, which lose antibiotic resistance associated with the vector. Determination of mutant allele exchange, as opposed to reversion to wild type, was screened by PCR amplification across the intergenic *luxR-luxI* region and digesting the amplified fragment. Conversion of ES114 to JB3 resulted in loss of an EcoRV site, whereas the difference between MJ1S and JB7 included addition of a BsaBI site. Putative double-crossover mutants were confirmed by cloning and sequencing of such PCR products.

Several loci were used as phylogenetic markers in *V. fischeri*. Sequences within *recA*, *mdh*, and *kata* were analyzed as previously reported (39). Briefly, *recA*, *mdh*, and *kata* were PCR amplified using primers pairs *recA*_whole_fw and *recA*_whole_rv, *mdh*_whole_fw and *mdh*_whole_rv, or *katA*_whole_fw and *katA*_whole_rv, respectively. The subsequent products were sequenced directly with primers *recA*610Wolfwd and *recA*610Wolrev (for *recA*), *mdh*_1_fw and *mdh*_1_rv (for *mdh*), or *katA*_2_fw and *katA*_3_rv (for *kata*). The intergenic region between divergently transcribed genes *glpA* and *fdh* (VFA0250 and

VFA0251) was amplified using primers EVS129 and EVS130, and the amplicons were cloned and sequenced.

Sequence analyses. For the housekeeping gene concatenation, the *glpA* and *fdh* intergenic region, the *luxR-luxI* intergenic region, the sequences obtained above, and the corresponding sequence from *V. salmonicida* LFI1238 (27) were aligned using the default pairwise and multiple alignment parameters in ClustalX 2.0.11 (30). The *luxI-luxR* intergenic region of *V. salmonicida* was too divergent to provide a reasonable alignment by machine or hand alignment (data not shown) and was not included in phylogenetic reconstructions of that region. The length of the individual sequences from *recA*, *mdh*, and *kata* concatenated for analysis after alignment and trimming were 690, 783, and 789 bp, respectively. Table S1 of the supplemental material provides the GenBank accession numbers for sequence data from each isolate; those accession numbers that are being reported for the first time here are also provided at the end of Materials and Methods.

Phylogenetic reconstructions were completed using three methods: maximum parsimony (MP), maximum likelihood (ML), and Bayesian inference. MP reconstructions were performed by treating gaps as missing, searching heuristically using simple addition, tree bisection reconnection for swaps, and swapping on “best only” with 1,000 repetitions. For ML and Bayesian analyses, likelihood scores of 56 potential evolutionary models were tested using the Akaike information criterion (AIC) as implemented by Modeltest 3.7 (51). Based on the AIC, a general time-reversible model with a gamma shape parameter and a proportion of invariable sites (GTR+ Γ +I) was chosen for *recA-mdh-kata* concatenation, a general time-reversible model with a gamma shape parameter (GTR+ Γ) was chosen for the *luxR-luxI* intergenic region, and the F81 model was chosen for the *glpA-fdhA* intergenic sequence. Maximum likelihood reconstructions were performed by treating gaps as missing, searching heuristically using simple addition, subtree pruning and regrafting (44) for swaps, and swapping on “best only” with 1,000 repetitions as implemented by PAUP*4.0b10 (70). Bayesian inference was done with an nst of 6 and rate invgamma settings (GTR+ Γ +I model) for *recA-mdh-kata*, an nst of 6 and rate gamma settings (GTR+ Γ model) for the *luxR-luxI* intergenic sequences, and an nst of 1 and rates set equal (F81 model) for the *glpA-fdhA* intergenic sequences with heated chains set to a temperature value of 0.20 (for all data, to ensure an appropriate amount of chain swapping) using the software package MrBayes 3.1.2 (53). Statistical analysis of clade membership/presence was assessed using either 1,000 bootstrap pseudoreplicates with the above search parameters (ML and MP) or by sampling an appropriately stationary posterior probability distribution every 1,000 generations (for *recA-mdh-kata*), 500 generations (for the *luxR-luxI* intergenic region), or 200 generations (for the *glpA-fdh* intergenic region). For our purposes, an appropriately stationary distribution was defined, as recommended by Ronquist and colleagues (54), as an average standard deviation of split frequencies of less than 0.01 for ~70 to 90% of samples between two independent Metropolis-coupled Markov

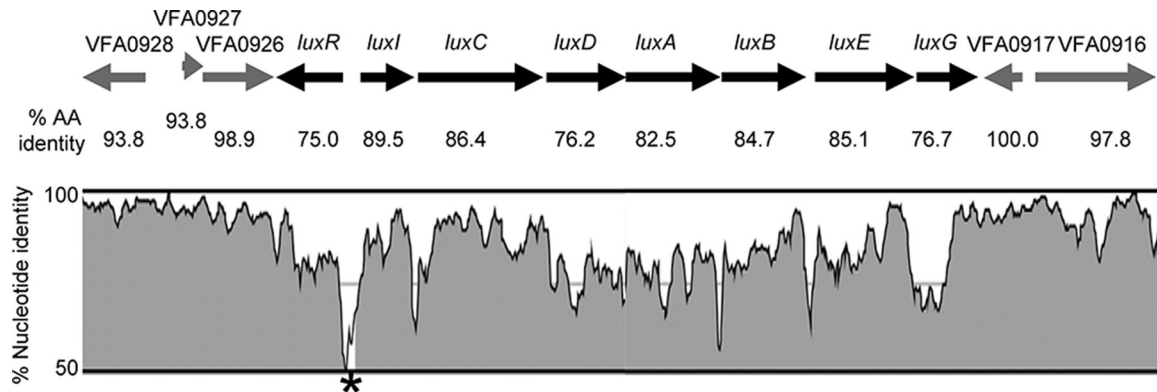

FIG. 1. Conservation of *lux* and flanking regions between *V. fischeri* strains ES114 and MJ11. The percent identity is shown for aligned nucleotides (on the y axis of the inset graph) and for encoded proteins as the percent amino acid (AA) identity below the corresponding gene. The black and gray arrows indicate the orientation of *lux* genes or flanking genes, respectively. Graphic representation of the percent nucleotide identity was generated with VISTA (40) and the LAGAN alignment program (9) using default settings. An asterisk marks an unshaded region between *luxI* and *luxR* where a window in the alignment falls below the 70% identity cutoff. Conservation of regions flanking the *lux* genes was typical for that extending several kilobases in each direction (data not shown).

chain Monte Carlo (MCMCMC) runs. Majority rule consensus trees drawn from the stationary sample distribution generated by MCMCMC were used for the assessment of the posterior probabilities of all clades. *V. salmonicida* LF11238 was used to root all reconstructions *post priori*, except for those involving the *luxR-luxI* intergenic data, which were midpoint rooted. Graphical reconstructions were drawn and edited with Figtree 1.3.1 (<http://tree.bio.ed.ac.uk/software/figtree/>) and Inkscape 0.47 (<http://www.inkscape.org/>).

The (null) hypothesis of neutral evolution in intergenic sequences was investigated using summary statistics, specifically, Tajima's *D* test statistic (71) as implemented in DnaSP 5.10 (34) with segregating sites considered. The statistical significance of the test statistic was assessed using DnaSP 5.10 by comparison to an empirical distribution of test statistics generated via the coalescent process and assuming no recombination with 10,000 replicates.

To compare the DNA of *lux* regions from MJ11 and ES114, we used VISTA (40) with the LAGAN (9) alignment function and default settings, including a 100-bp window for calculating identity. We used BLAST (2) to align protein sequences and calculate the percent identity.

lacZ reporter expression. To determine *lacZ* reporter expression, strains were grown in 25 ml SWTO in 125-ml flasks at 24°C with shaking to an OD of ~3.0. Culture samples were taken, cells were pelleted, the supernatant was discarded, and the pellet was frozen at -20°C. The pellet was thawed and resuspended in Z-buffer for determination of β -galactosidase activity, expressed as Miller units as previously described (42). The promoterless *lacZ* vector pAKD702 was included as a negative control. Whether the group of $P_{luxR-lacZ}$ or $P_{luxI-lacZ}$ reporters showed significantly different activities between host strains ES114, H905, and WH1 was determined using Student's *t* test. Associations between promoter-reporter activity and the luminescence of the strain from which the promoter was cloned were determined using Spearman's rank correlation test.

Nucleotide sequence accession numbers. The newly identified nucleotide sequences for *recA*, *mdh*, *katA*, the *luxR-luxI* intergenic region, and the *glaA-fdhA* intergenic region have been deposited with GenBank and assigned accession numbers HQ595306 to HQ595321, HQ595322 to HQ595330, HQ595331 to HQ595339, HQ436468 to HQ436485, and HQ535984 to HQ535999, respectively.

RESULTS

Comparison between bright strain MJ11 and dim strain ES114. Genomic sequences of the bright *V. fischeri* strain MJ11 (38, 39) and the relatively dim strain ES114 (58) allowed us to compare the *luxR-luxICDABEG* region and several kb flanking *lux*, as well as global genetic interstrain differences. Thus, while previous studies had compared *lux* operons between strains (22), the availability of genomic data and sequence analysis tools allowed us to place such a comparison in a broader context. As we previously noted, there is a high degree of sequence conservation between ES114 and MJ11 (39). This

was true in the region of chromosome II surrounding *luxR-luxICDABEG*; however, the *lux* region itself was more highly diverged, both in terms of nucleotide sequence and encoded proteins (Fig. 1). On average, orthologs in ES114 and MJ11 share greater than 95% identity, and this was true in open reading frames (ORFs) surrounding the *lux* region, such as VFA0916-VFA0917 and VFA0926-VFA0928 (Fig. 1). On the other hand, LuxR and the proteins encoded by the *luxICDABEG* operon share only 75.0 to 89.5% identity between ES114 and MJ11, while fewer than 5% of the orthologs shared by ES114 and MJ11 are so greatly diverged (Fig. 1) (see also the supplementary material in reference 39). Examination of other encoded proteins known to participate in *lux* regulation (Table 3) showed that most had a high degree of conser-

TABLE 3. Conservation of selected luminescence regulators between ES114 and MJ11

Regulator	ORF(s) in ES114	Proposed regulatory role ^a	% amino acid identity between ES114 and MJ11
AinS	VF1037	C8-HSL	83.1
AinR	VF1036	C8-HSL	91.7
LuxS	VF0545	AI-2	99.4
LuxP	VF0707	AI-2	98.1
LuxQ	VF0708	AI-2	98.2
LuxU	VF0937	AI-2/C8-HSL	99.2
LuxO	VF0938	AI-2/C8-HSL	99.8
LitR	VF2177	AI-2/C8-HSL	99.5
Hfq	VF2323	AI-2/C8-HSL	100.0
<i>qrr1</i> ^b	NA	AI-2/C8-HSL	100.0
LonA	VF0798	Degradation of LuxR	99.7
ArcB/ArcA	VF2122/VF2120	Environmental	98.7/100.0
GacS/GacA	VF2082/VF1627	Environmental	99.4/100.0
CRP	VF2280	Environmental	100.0
PhoB	VF1988	Environmental	99.6

^a Notations indicate proposed roles in luminescence regulation through C8-HSL, AI-2, both of these autoinducers (AI-2/C8-HSL), degradation of the HSL-responsive activator LuxR, or the sensing of environmental stimuli and signal transduction.

^b *qrr1* is a small RNA and therefore an open reading frame description is not applicable (NA), and the percent nucleotide identity (not amino acid identity) is presented.

vation typical of shared orthologs, with the notable exception of the AinS/AinR autoinducer system, which has also diverged more than average.

Sequence divergence within *luxR-luxICDABEG* was particularly noteworthy in the intergenic *luxR-luxI* region (Fig. 1). Although one might expect less conservation of noncoding sequences, intergenic regions similarly situated between divergent genes were typically more highly conserved, as is illustrated by the sequences between VFA0916 and VFA0917 or between VFA0927 and VFA0928 (Fig. 1).

Analysis of the *luxR-luxI* intergenic region and bioluminescence among diverse strains. To explore the evolution of intergenic *luxR-luxI* sequences more closely, we cloned, sequenced, and analyzed this region from a collection of strains (Table 1). This collection of diverse *V. fischeri* strains included isolates from fish, such as *Cleidopus gloriamaris* and *Monocentris japonica*, squid of both the *Euprymna* and *Sepiolo* genera, and planktonic isolates (Table 1).

An alignment of the *luxR-luxI* intergenic sequences in these strains is shown in Fig. 2. Of the 222 positions in the alignment between the start codons of LuxR and LuxI, only 104 positions (47%) were conserved among all of the strains. Pairwise comparisons of this region between the strains ranged from 60 to 100% sequence identity. In many instances, conserved sequences among all strains represented established binding sites for regulators. For example, the Lux box binding site for LuxR is well conserved across the strains (Fig. 2). There are only two consistent differences in the Lux box between the nonvisible (NV) and highly visible (HV) strains, and in another study these base pair changes had relatively little influence on promoter activity, with the slight effects being roughly equal and opposite (3). Similarly, CRP was previously shown to bind within the intergenic *lux* region (61), where it appears to regulate *luxR* transcription (11, 12), and a sequence corresponding to this binding site and resembling the consensus core recognition sequence for CRP [5'-AATTGTGA(N6)TCACAATT-3'] is conserved (Fig. 2), although divergence in this sequence may also reflect varied affinities for CRP binding. Likewise, the ArcA-binding consensus core (5'-ATGTTAA-3') is found adjacent to the Lux box on the reverse strand relative to *luxI* in all strains (Fig. 2), consistent with our report that ArcA binds this location and regulates luminescence (7). Another conserved feature that stood out is a palindromic repeat nearer *luxR* (Fig. 2), although its function is unknown. In addition, there were many differences between the strains, and perhaps the most notable was a direct repeat of 5'-CTTTATC-3' near the *luxR* start codon present in MJ11 and MJ1S but lacking in other strains, including MJ1.

A phylogenetic reconstruction of the evolutionary relationships among intergenic *luxR-luxI* sequences is also shown, juxtaposed against the quantified luminescence phenotypes of the respective strains, in Fig. 3. As has been done in the past, strains were scored qualitatively as producing nonvisible (NV), visible (V), or highly visible (HV) luminescence (Fig. 3). It should be emphasized that even NV strains did exhibit detectable bioluminescence. Examination of the tree shows two distinct clades. One clade includes all the fish isolates, *Sepiolo* squid isolates, and the planktonic strain WH1. This group encompasses all the strains classified as HV. The second clade includes all of the isolates from the Hawaiian bobtail squid,

Euprymna scolopes. For the most part the isolates from *E. scolopes* group closely together with the Hawaiian planktonic isolate PP3, which was previously shown to resemble isolates from *E. scolopes* (31–33). The remainder of this clade includes isolates ET401, EM17, and ET101 from other *Euprymna* species found in Japan or Australia, as well as two Hawaiian isolates, VLS2 and H905, which are unusual for that locale and are not proficient colonizers of *E. scolopes* (31–33). The latter set of isolates includes all but one classified as visibly luminescent in Table 1, V class strain PP3.

Also reported in Fig. 3 is the luminescence of the *V. fischeri* strains on solid media and in broth. Not surprisingly, there was a strong correlation between the luminescence intensity of cells collected from solid media and luminescence classification based on observations of plates (Fig. 3). Based on these data, it appears that the threshold amount of light produced that is required for the visible classification falls somewhere between the bioluminescence produced by PP3 (V) and that of ES401 (NV). Generally, specific luminescence was higher in broth culture than during growth on solid media; however, VLS2, H905, and SR5 produced similar luminescence levels under both conditions, and ET101 had higher luminescence on solid media than in broth. Upon comparing Fig. 2 and 3, we found that ES12 and ES213 have identical *luxR-luxI* intergenic regions, yet ES213 produces 100-fold and 1,000-fold more light on plates and in broth, respectively. Thus, two strains having identical *luxR* and *luxICDABEG* promoters may produce very different amounts of light. Further examination of the broth cultures during growth showed that all of the strains were subject to cell density-dependent regulation of luminescence (data not shown).

Comparison of *luxR-luxI* intergenic divergence with that of housekeeping loci. In order to better understand if there was any significance to the high nucleotide diversity among the *luxI-luxR* intergenic sequences, we sequenced the intergenic region between *glpA* and *fdhA* in our collection of *V. fischeri* strains. Like *luxR* and *luxI*, these genes are adjacent and divergently transcribed on chromosome 2. Phylogenetic reconstruction and statistical analyses of evolutionary relationships among *glpA-fdhA* intergenic sequences allowed an interesting comparison to results from similar analyses of the *luxR-luxI* intergenic region. Each of the *V. fischeri* strains listed in Table 1 had a 298-bp intergenic region between *glpA* and *fdhA*, and 289 bp (97%) were conserved among all the strains. Pair-wise comparisons of this region between the strains ranged from 98 to 100% sequence identity. Thus, as was the case between divergently transcribed genes near *lux* (VFA0916 and VFA0917 or VFA0927 and VFA0928 [Fig. 1]), this intergenic region is far more conserved than the *luxR-luxI* intergenic region. We generated a phylogenetic reconstruction of *V. fischeri* strains based on the intergenic *glpA-fdhA* region (Fig. 4). Given the lack of differences between the strains in this intergenic region, nodes of this tree were not supported by strong bootstrap values; however, four of the strains in one of the clades, namely, MJ1S, MJ11, WH1, and SR5, did appear to form a distinct well-supported branch (Fig. 4).

One hypothesis from the above phylogenetic results is that the *luxR-luxI* intergenic region is under different selective pressure than that of a “normal” housekeeping intergenic sequence on chromosome 2 of *V. fischeri*. To examine

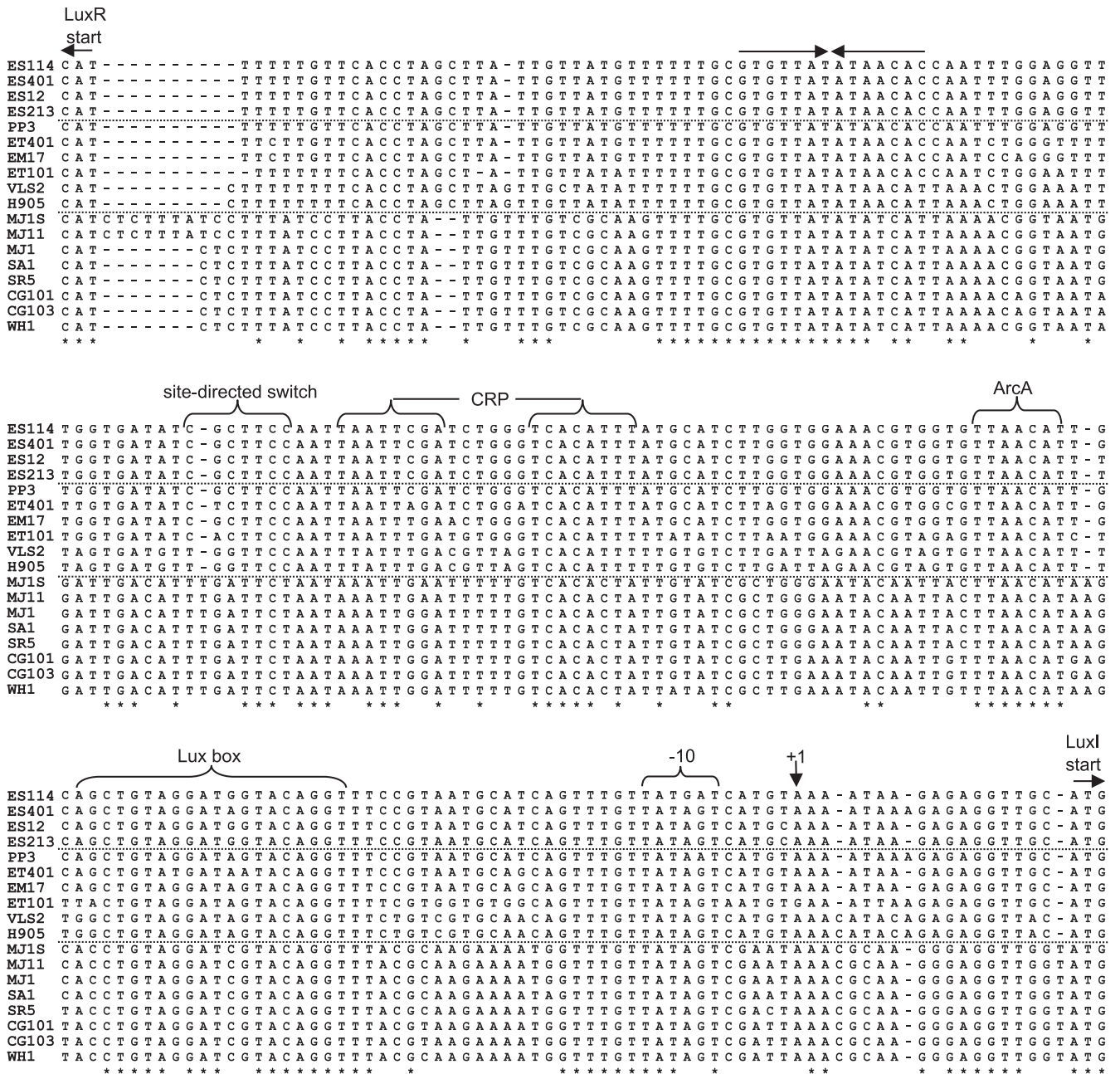

FIG. 2. Alignment of *lux* intergenic regions from diverse *V. fischeri* strains. Horizontal dashed lines separate strains with luminescence on plates classified as nonvisible (ES114, ES401, ES12, and ES213), visible (PP3, ET401, EM17, ET101, VLS2, and H905), or highly visible (MJ1S, MJ11, MJ1, SA1, SR5, CG101, CG103, and WH1). Asterisks mark bases conserved across all strains. Labeled arrows mark the translational start sites for LuxI and LuxR (on the reverse strand). The transcriptional start site for *luxICDABEG* determined in ES114 (16) is marked +1 and with a vertical arrow, and the corresponding -10 promoter element is indicated. Core consensus sequences for CRP, ArcA, and LuxR binding are shown and are discussed further in the text. A pair of arrows above the top row of the sequences indicates the position of an inverted repeat. The region labeled the site-directed switch was engineered such that this sequence in ES114 was placed in MJ1S to generate strain JB7 and, likewise, switched from MJ1S into ES114 to generate strain JB3.

this hypothesis, the summary Tajima's *D* statistic (and its statistical significance) was calculated for each group of intergenic sequences (Table 4). The null hypothesis for this test statistic is that for a given random sample of a population, the sequence analyzed is dominated by genetic drift and has evolved under a predominantly neutral model (Tajima's *D* = 0). This null hypothesis was rejected for the

luxR-luxI intergenic sequence, but not for the intergenic *glpA-fdhA* region (Table 4). This positive, statistically significant value of the *D* test statistic for the *luxI-luxR* region suggests that population demographics and/or balancing selection has caused an excess of intermediate-frequency polymorphisms in the set of sequences analyzed relative to that of an intergenic region such as the *glpA-fdhA* region (52).

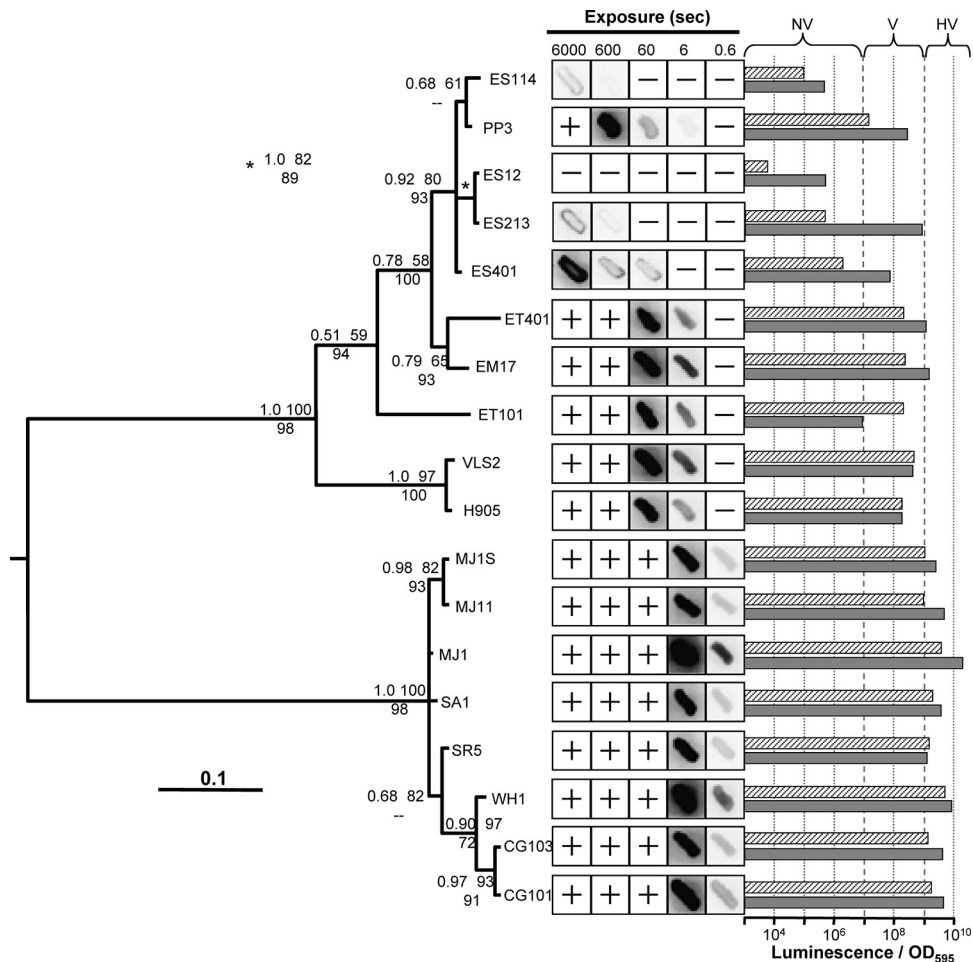

FIG. 3. Relatedness of the *luxR-luxI* intergenic sequence in *V. fischeri* isolates. The topology represents the 50% majority rule consensus tree generated from a Bayesian analysis. Statistical support of each node is given at the particular node based on three values: Bayesian posterior probability (upper left); ML bootstrap support values (1,000 pseudoreplicates) (upper right); MP bootstrap support values (1,000 pseudoreplicates) (lower center). Dashes indicate clade support of <50% for 1,000 MP bootstrap pseudoreplicates. The tree was mid-point rooted. Bar, 0.1 substitutions per site. Patches were grown overnight on SWTO at 24°C, and the negative images for given exposures are shown. A + or – indicates that luminescence was too high or low to see clearly, respectively. Horizontal bars display the luminescence per OD₅₉₅ unit of each strain grown on plates for 18 h and resuspended (hatched bars) or grown in broth with peak luminescence reported (solid bars). Dashed vertical lines indicate approximate cutoffs that were used to distinguish strains that produced nonvisible, visible, or highly visible luminescence on SWTO plates.

To better compare the phylogeny of our strain collection to the evolutionary history of *lux* intergenic sequences, we sequenced portions of *recA*, *katA*, and *mdh*. The concatenated sequences of these housekeeping genes were used to reconstruct the evolutionary relationships among *V. fischeri* strains in a manner independent from intergenic sequences (Fig. 5). The topology of the phylogenetic reconstruction inferred from these housekeeping genes was generally similar to the topology of the *luxI-luxR* intergenic sequence reconstruction (Fig. 3). One notable exception was strain MJ1, which groups with other HVL strains according to *lux* sequence (Fig. 3) but not in phylogeny (Fig. 5). This is consistent with the observation noted above that the intergenic *glpA-fdhA* region of MJ1 is distinct from that of MJ1S and MJ11. Moreover, this general pattern seen with the *glpA-fdhA* region and the concatenated sequences was also observed for phylogenetic reconstructions made from each of the *recA*, *katA*, and *mdh* loci individually (data not shown). Overall, the phylogenetic reconstruction of

this strain collection appears to show two distinct clades of *V. fischeri*, which resembles the clear bifurcation reported in other recent studies (4, 39).

Differences in intergenic *luxR-luxI* sequences affect *luxI* promoter strength and bioluminescence. Given the high substitution rate in the *luxR-luxI* intergenic region (Fig. 1, 2, and 3) and the correlation between these sequences and luminescence output (Fig. 3), we hypothesized that the strength of the *luxR* and/or *luxI* promoters might underlie some of the differences in luminescence. To begin testing this hypothesis, we constructed P_{*luxI*}-*lacZ* and P_{*luxR*}-*lacZ* reporter plasmids (Table 1). These reporters were derived from *V. fischeri* plasmid pES213 (13), which is very stable in strain ES114 (14); however, we found that they were not stable in all *V. fischeri* (data not shown). For example, our pES213 derivatives were not stable in MJ11, which was recently discovered to harbor a very large and unique plasmid absent in ES114 (38). Accordingly, we only considered data from strains in which the reporters are stably

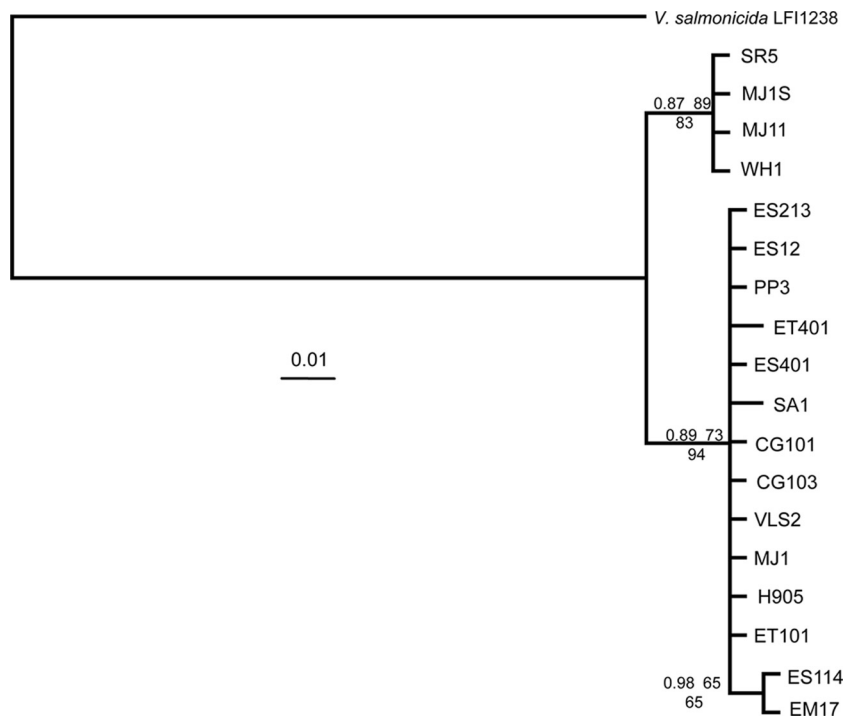

FIG. 4. Bayesian phylogeny of the intergenic *glpA-fdhA* region among *V. fischeri* isolates. The topology was generated as described for Fig. 3, and the statistical support values given at each node were calculated and are placed in order as for Fig. 3. The tree was rooted with the corresponding sequence from *V. salmonicida* LFI1238. Bar, 0.01 substitutions per site. This reconstruction's low resolution is a result of low sequence diversity among isolates.

maintained in the absence of selection. We also considered the possibility that differences in plasmid copy number or endogenous β -galactosidase activity (1) might invalidate interstrain comparisons using these reporters. Therefore, as controls we included a promoterless reporter as well as plasmids with *lacZ* strongly expressed from a consensus promoter or weakly expressed from a construct where the consensus promoter was oriented away from *lacZ*. We found that background β -galactosidase activity was undetectable and that activities from our synthetic promoter constructs were similar in different *V. fischeri* backgrounds (data not shown), indicating that it would be reasonable to make comparisons using P_{luxI} -*lacZ* and P_{luxR} -*lacZ* reporter plasmids in distinct *V. fischeri* strains. On the other hand, β -galactosidase activities from the synthetic promoter-*lacZ* constructs were somewhat lower in *E. coli* (data not shown), and so the lower

activity of the P_{luxI} -*lacZ* and P_{luxR} -*lacZ* reporters in *E. coli* versus *V. fischeri* is not a meaningful comparison.

The P_{luxI} -*lacZ* and P_{luxR} -*lacZ* reporters were examined in *E. coli* DH5 α as well as in *V. fischeri* strains ES114, H905, and WH1, which represent NV, V, and HV luminescence classes, respectively. The β -galactosidase activities from the 15 distinct sets of P_{luxI} -*lacZ* and P_{luxR} -*lacZ* reporters in the four host strains are shown along with the source of the promoter sequence in Fig. 6A and B. The activities of these reporters are also displayed (Fig. 6C and D) as a function of the luminescence of the strain(s) serving as the source of the P_{luxI} or P_{luxR} promoter in the reporter. Expression from the P_{luxI} -*lacZ* reporters showed a significant ($P < 0.01$) trend toward higher activity in strains H905 and WH1 than in ES114 (Fig. 6A), which perhaps not surprisingly indicates that in general *luxI* promoters from any source are more highly expressed in relatively bright strains. More interestingly, in each of the *V. fischeri* host strains, expression from the *luxI* reporters tended to correlate ($P < 0.02$ in each *V. fischeri* host) with the luminescence of the strain from which the promoter was derived (Fig. 6C), suggesting that the intrinsic strength of the *luxI* promoter tends to be higher when it is from a brighter strain, regardless of the *V. fischeri* host strain for the reporter. This trend was not evident ($P = 0.99$) when the reporters were placed in *E. coli* (Fig. 6C). Moreover, neither the luminescence of the host strain nor that of the source strain(s) for *luxR* promoters was positively correlated with reporter activity, and if anything, *luxR* reporter expression was slightly higher in the relatively dim strain ES114 (Fig. 6B and D).

TABLE 4. Analysis of intergenic sequences based on Tajima's *D* test statistic

Intergenic sequence	n^a	S^b	π^c	D^d	95% CI ^e	<i>P</i> value ^f
<i>luxI-luxR</i>	18	108	0.23558	2.38938	1.66, -1.75	0.002
<i>glpA-fdhA</i>	18	9	0.00864	0.01467	1.82, -1.79	0.435

^a The number of sequences.

^b The number of segregating sites.

^c π indicates nucleotide diversity.

^d Tajima's *D* test statistic.

^e The 95% confidence interval (CI) for distribution of 10,000 simulations of the test statistic using coalescent simulations.

^f The *P* value was assessed using the coalescent generated test statistic distribution.

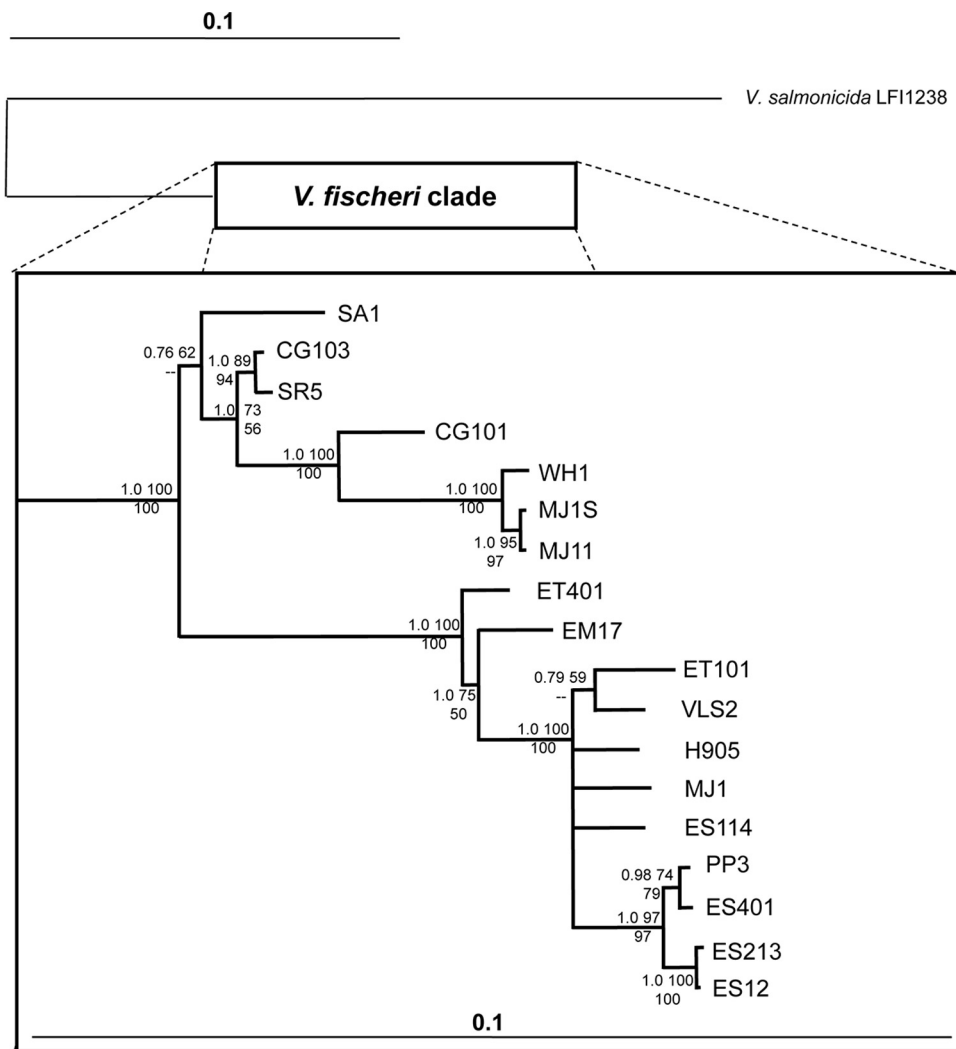

FIG. 5. Bayesian phylogeny of concatenated *recA-katA-mdh* sequences among *V. fischeri* isolates. The topology was generated as described for Fig. 3, and the statistical support values given at each node were calculated and placed in order as for Fig. 3. The tree was rooted with the corresponding sequences from *V. salmonicida* LFI1238. Bars, 0.1 substitutions per site; the *V. fischeri* clade was expanded in order to more easily view fine-scale topological resolution among all isolates.

The results above led us to hypothesize that differences in the *luxR-luxI* intergenic region might underlie a considerable amount of the strain-specific variation in luminescence output. To test this directly, we exchanged a short (7- to 8-bp) sequence on the chromosome in the *luxR-luxI* intergenic region between the relatively bright (HV) strain MJ1S and the relatively dim (NV) strain ES114. The sequence exchanged between these strains is shown in Fig. 2 (labeled site-directed switch). This sequence was targeted because it was suspected of involvement in FNR-mediated regulation that might be strain specific; however, more recently we (and others) found no evidence of a direct regulation of *lux* promoters by FNR (60). This short intergenic sequence from ES114 was placed in MJ1S to generate strain JB7, and likewise, the corresponding sequence from MJ1S was placed in ES114 to generate strain JB3. The striking results were that JB3 is more than 100-fold brighter than its parent ES114, and JB7 is more than a 100-fold dimmer than its parent MJ1S (Fig. 7). Indeed, JB3 is more than 10-fold brighter than JB7 (Fig. 7), despite the fact that

JB3 is derived from the much dimmer ES114. These shifts in luminescence were observed regardless of the *fir* genotype under both well-aerated and anaerobic conditions (data not shown). This result indicates that changes in the *luxR-luxI* intergenic region can have large effects on luminescence output in an otherwise-isogenic background.

DISCUSSION

The functional significance of bioluminescence for light-producing bacteria remains a controversial topic (62), and it is made all the more mysterious by the wide variation in light output by different environmental isolates, ranging from brightly visible to “cryptic.” Some bioluminescent members of the *Vibrionaceae* are not known to have any specific light organ hosts to make use of the light they produce. These strains can be free living but are also isolated frequently from fish gut tracts, where their luminescence may be valuable in making fecal matter visible to potential new hosts (46). Such strains

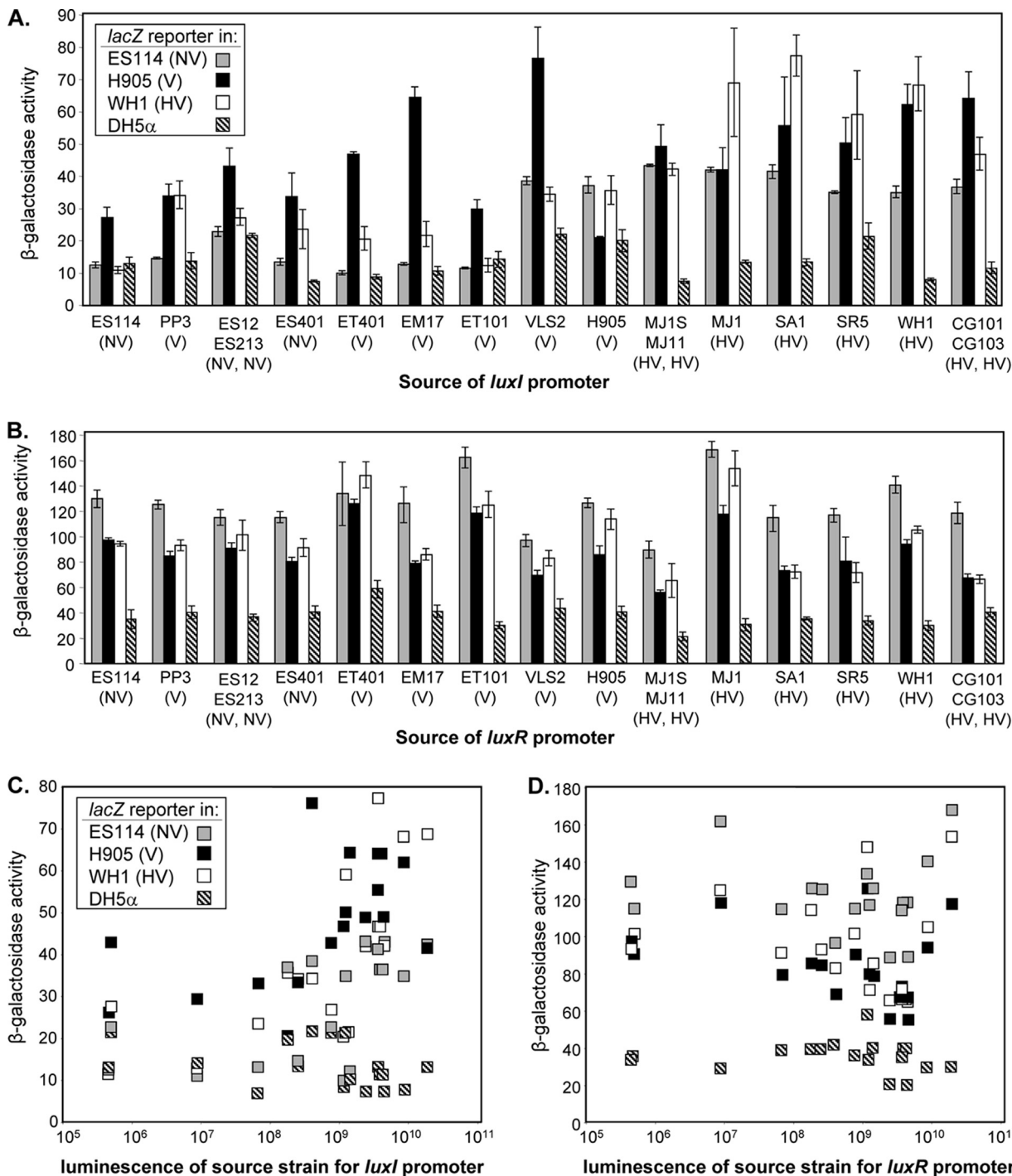

FIG. 6. Activity of *lux* promoter reporters. The β -galactosidase activities (in Miller units) from specific P_{luxI} -*lacZ* and P_{luxR} -*lacZ* constructs are shown for reporters carried in *V. fischeri* strains ES114 (gray), H905 (black), and WH1 (open) as well as in *E. coli* DH5 α (hatched lines). The luminescence class of the *V. fischeri* strains (Table 1) is indicated in parentheses as NV, V, or HV. (A and B) The strain(s) corresponding to the promoter sequence in P_{luxI} -*lacZ* and P_{luxR} -*lacZ* constructs, respectively, and these are arranged (left to right) in the same order as the strains shown in Fig. 3 (top to bottom). (C and D) Reporter activity is plotted as a function of the luminescence of the source strain(s) for P_{luxI} -*lacZ* and P_{luxR} -*lacZ* promoters, respectively. Data from different experiments with treatments in common and with similar results were pooled, and averages are reported (panels A and B also show standard errors [$n = 3$]).

can be bright or dim, and it is not clear how or why any of them would have evolved and retained attenuated dim luminescence. *V. fischeri* does have mutualistic symbiotic hosts, and strains of this species also vary considerably in luminescence

(Fig. 3). At least for *V. fischeri*, there appears to be a plausible explanation for differences in luminescence output. Specifically, some *V. fischeri* strains have evolved symbioses with fishes for which light is thought to be used by the host in bright

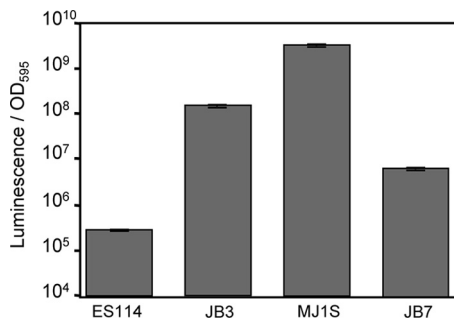

FIG. 7. Exchanging a short stretch of the *luxI-luxR* intergenic region between ES114 and MJ1S largely reverses their relative brightness. Luminescence per OD₅₉₅ unit is shown for cultures of ES114, JB3, MJ1S, and JB7 grown in SWTO broth at 24°C with shaking (200 rpm). Data are the average peak luminescence levels per OD₅₉₅ unit, with standard errors ($n = 2$).

signaling behaviors, whereas in other strains luminescence may provide a dim counterilluminating camouflage (28, 46, 65). However, this does not explain the mechanistic underpinnings of luminescence variability.

Despite the wide variation in luminescence output by different environmental isolates of *V. fischeri*, the general makeup and arrangement of the genes responsible for luminescence appear to be conserved in dim and bright strains (22), raising the question of how this phenotypic divergence evolved. We have found that the *lux* and *ainSR* loci of bright and dim *V. fischeri* strains have diverged in sequence far more than most orthologs. This observation is consistent with selective pressure(s) on luminescence output and suggests relatively rapid evolution of the loci underlying bioluminescence and pheromone production. The divergence of the *luxI-luxR* intergenic region is particularly striking (Fig. 1 and 2), and we have shown that variation in this region has resulted in a correlation between *luxI* promoter strength and strain brightness (Fig. 6). Moreover, exchanging a small (<10-bp) part of the *luxI-luxR* intergenic region between two strains largely reversed their relative luminescence levels. Although it is clear that other factors influence luminescence output, as discussed below, our data clearly demonstrate that much of the difference in strain luminescence can be attributed to this regulatory control region.

Conservation in the *luxR-luxI* intergenic region highlights key regulatory regions. Comparison of the *luxR-luxI* intergenic region further revealed conserved regulatory sites. While some, such as the Lux box and ArcA-binding sites, were previously known, at least one potential new regulatory site was identified. Specifically, there is a region near *luxR* that includes an absolutely conserved 5'-TTTGC-3' sequence adjacent to a highly conserved palindromic repeat of 5'-GTGTTAT/ATAACAC-3' (Fig. 2). This palindrome is perfectly conserved in all NV and some V strains, has one mismatch in other V strains, and two mismatches in VL strains. The function of this conserved sequence, if any, is unknown; however, its location is consistent with it serving as the binding site for LitR, which previously was mapped to a 427-bp fragment on the *luxR* side of the Lux box (19). Little is known about LitR, but its homolog in *Vibrio harveyi* (named LuxR in that organism, and referred to here as LuxR^{Vh}) has been analyzed more exten-

sively. Swarzman and Meighan proposed a 5'-AGTGTTAC-3' consensus binding sequence for LuxR^{Vh} (69), which is remarkably similar to half of the palindrome described above. On the other hand, a more recent and thorough analysis of LuxR^{Vh} binding revealed a quite different recognition sequence (50). The approach used in the earlier study leaves open the possibility that the consensus sequence those authors reported reflects another regulatory sequence that does not directly interact with LuxR^{Vh} but is overlapped by its footprint in the same promoters. Similarly, the conserved palindrome in *V. fischeri* may reflect a regulatory mechanism that works in concert with LitR rather than by binding LitR itself. Further experimentation will be required to distinguish between these possibilities.

Importance of sequences outside the *luxR-luxI* intergenic region. Our results also indicate that regions outside the *luxI* and *luxR* promoters can influence luminescence. This was illustrated in a comparison of strains ES12 and ES213, which have identical *luxR-luxI* intergenic regions but differ in luminescence output by orders of magnitude. The disparate luminescence in these strains, and others, may be due in part to functional differences in the Lux proteins, different levels of other *lux*-regulating proteins, posttranscriptional regulation, or differences in cell physiology. In this regard, a comparison of coding sequences between ES114 and MJ11 showed notable divergence in LuxI, LuxR, the light-generating Lux proteins, and the AinS/AinR system, and it seems likely that these differences may underlie some of the disparity seen in luminescence output.

Convergence of directed and real-world evolution in LuxR. Another noteworthy example of interstrain differences outside the *luxR-luxI* intergenic region involves LuxR. Directed evolution of *luxR* from MJ1 in the laboratory has revealed LuxR variants with altered responsiveness to various homoserine lactones (10, 25), and two LuxR alleles (T33A and I96V) that were isolated based on increased responsiveness to the *V. fischeri* autoinducer C8-HSL (10) are also found in the native ES114 LuxR. In other words, one of the differences we found between the LuxRs encoded by ES114 and MJ1 was already discovered as conferring responsiveness to C8-HSL on MJ1's LuxR. ES114 produces more C8-HSL than does MJ1 (68), so perhaps C8-HSL and 3-oxo-C6-HSL have evolved different roles in distinct *V. fischeri* clades, and this may be reflected in the LuxR proteins.

***V. fischeri* as a model for future evolutionary studies of luminescence.** Bioluminescence is a trait scattered throughout the family *Vibrionaceae*; however, the selective pressures driving the evolution of bioluminescence are not always clear (62). As noted here, the mystery deepens in that light output can vary by over several orders of magnitude between different environmental isolates of *V. fischeri*, and this is true for other *Vibrio* species as well (23, 49). The work here provides evidence that *lux* has evolved relatively rapidly in *V. fischeri* and helps provide a foundation for understanding the mechanistic differences leading to dimmer or brighter strains. Moreover, bioluminescence contributes to fitness of *V. fischeri* in its symbiotic environment (8, 73), and this symbiosis can be reconstituted in the laboratory (55, 63), affording the opportunity to assess the consequences of genetic changes to the *lux* system under ecologically relevant growth conditions. Interestingly, when MJ11 colonized squid, the animals were much brighter

than those colonized by native symbionts (39, 59), which would theoretically disrupt the advantages of dim counterillumination. Preliminary evidence was recently presented that suggested that when MJ11 was grown for multiple generations in association with its nonnative host *E. scolopes*, most of the squid-adapted strains became dimmer, resembling natural isolates from *E. scolopes* (59). This could indicate a selection against the energetic costs of bright bioluminescence when it confers no advantage; however, the relatively rapid loss of bright bioluminescence in the squid as opposed to findings in culture suggests a positive selection for dimness in this host. Further work with such evolved strains, along with more mechanistic studies, will help shed light on the evolution and importance of bioluminescence in the model bacterium *V. fischeri*.

ACKNOWLEDGMENTS

We thank Edward G. Ruby for helpful discussions, E. Peter Greenberg for providing MJ1, Danielle Britt for technical assistance, and several volunteers who ranked strain bioluminescence levels in a dark-room.

This work was supported by the National Science Foundation (NSF) under grant CAREER MCB-0347317 to E.V.S. M.S.W. was supported by a grant (RR12294) to E.G. Ruby from the National Institutes of Health (NIH) and by a training grant from the NIH (5 T32 GM007215-35). A.N.S. was supported by a National Defense Science and Engineering Graduate Fellowship.

Genomic information was provided through the support of the W. M. Keck Foundation (strain ES114) and the Gordon and Betty Moore Foundation (strain MJ11).

REFERENCES

- Adin, D. M., K. L. Visick, and E. V. Stabb. 2008. Identification of a cellobiose utilization gene cluster with cryptic beta-galactosidase activity in *Vibrio fischeri*. *Appl. Environ. Microbiol.* **74**:4059–4069.
- Altschul, S. F., W. Gish, W. Miller, E. W. Myers, and D. J. Lipman. 1990. Basic local alignment search tool. *J. Mol. Biol.* **215**:403–410.
- Antunes, L. C., R. B. Ferreira, C. P. Lostroh, and E. P. Greenberg. 2008. A mutational analysis defines *Vibrio fischeri* LuxR binding sites. *J. Bacteriol.* **190**:4392–4397.
- Ast, J. C., H. Urbanczyk, and P. V. Dunlap. 2009. Multi-gene analysis reveals previously unrecognized phylogenetic diversity in *Aliivibrio*. *Syst. Appl. Microbiol.* **32**:379–386.
- Boettcher, K. J., and E. G. Ruby. 1990. Depressed light emission by symbiotic *Vibrio fischeri* of the sepiolid squid *Euprymna scolopes*. *J. Bacteriol.* **172**:3701–3706.
- Boettcher, K. J., and E. G. Ruby. 1994. Occurrence of plasmid DNA in the sepiolid squid symbiont *Vibrio fischeri*. *Curr. Microbiol.* **29**:279–286.
- Bose, J. L., et al. 2007. Bioluminescence in *Vibrio fischeri* is controlled by the redox-responsive regulator ArcA. *Mol. Microbiol.* **65**:538–553.
- Bose, J. L., C. S. Rosenberg, and E. V. Stabb. 2008. Effects of *luxCDABEG* induction in *Vibrio fischeri*: enhancement of symbiotic colonization and conditional attenuation of growth in culture. *Arch. Microbiol.* **190**:169–183.
- Brudno, M., et al. 2003. LAGAN and Multi-LAGAN: efficient tools for large-scale multiple alignment of genomic DNA. *Genome Res.* **13**:721–731.
- Collins, C. H., F. H. Arnold, and J. R. Leadbetter. 2005. Directed evolution of *Vibrio fischeri* LuxR for increased sensitivity to a broad spectrum of acyl-homoserine lactones. *Mol. Microbiol.* **55**:712–723.
- Dunlap, P. V., and E. P. Greenberg. 1985. Control of *Vibrio fischeri* luminescence gene expression in *Escherichia coli* by cyclic AMP and cyclic AMP receptor protein. *J. Bacteriol.* **164**:45–50.
- Dunlap, P. V., and E. P. Greenberg. 1988. Control of *Vibrio fischeri* *lux* gene transcription by a cyclic AMP receptor protein-LuxR protein regulatory circuit. *J. Bacteriol.* **170**:4040–4046.
- Dunn, A. K., M. O. Martin, and E. V. Stabb. 2005. Characterization of pES213, a small mobilizable plasmid from *Vibrio fischeri*. *Plasmid* **54**:114–134.
- Dunn, A. K., D. S. Millikan, D. M. Adin, J. L. Bose, and E. V. Stabb. 2006. New *rfp*- and pES213-derived tools for analyzing symbiotic *Vibrio fischeri* reveal patterns of infection and *lux* expression in situ. *Appl. Environ. Microbiol.* **72**:802–810.
- Eberhard, A., et al. 1981. Structural identification of autoinducer of *Photobacterium fischeri* luciferase. *Biochemistry* **20**:2444–2449.
- Egland, K. A., and E. P. Greenberg. 1999. Quorum sensing in *Vibrio fischeri*: elements of the *luxI* promoter. *Mol. Microbiol.* **31**:1197–1204.
- Engebrecht, J., K. Neelson, and M. Silverman. 1983. Bacterial bioluminescence: isolation and genetic analysis of functions from *Vibrio fischeri*. *Cell* **32**:773–781.
- Engebrecht, J., and M. Silverman. 1984. Identification of genes and gene products necessary for bacterial bioluminescence. *Proc. Natl. Acad. Sci. U. S. A.* **81**:4154–4158.
- Fidopiastis, P. M., C. M. Miyamoto, M. G. Jobling, E. A. Meighen, and E. G. Ruby. 2002. LitR, a new transcriptional activator in *Vibrio fischeri*, regulates luminescence and symbiotic light organ colonization. *Mol. Microbiol.* **45**:131–143.
- Fidopiastis, P. M., H. Sorum, and E. G. Ruby. 1999. Cryptic luminescence in the cold-water fish pathogen *Vibrio salmonicida*. *Arch. Microbiol.* **171**:205–209.
- Fidopiastis, P. M., S. von Boletzky, and E. G. Ruby. 1998. A new niche for *Vibrio loeferi*, the predominant light organ symbiont of squids in the genus *Sepiola*. *J. Bacteriol.* **180**:59–64.
- Gray, K. M., and E. P. Greenberg. 1992. Physical and functional maps of the luminescence gene cluster in an autoinducer-deficient *Vibrio fischeri* strain isolated from a squid light organ. *J. Bacteriol.* **174**:4384–4390.
- Grim, C. J., et al. 2008. Occurrence and expression of luminescence in *Vibrio cholerae*. *Appl. Environ. Microbiol.* **74**:708–715.
- Hanahan, D. 1983. Studies on transformation of *Escherichia coli* with plasmids. *J. Mol. Biol.* **166**:557–580.
- Hawkins, A. C., F. H. Arnold, R. Stuermer, B. Hauer, and J. R. Leadbetter. 2007. Directed evolution of *Vibrio fischeri* LuxR for improved response to butanoyl-homoserine lactone. *Appl. Environ. Microbiol.* **73**:5775–5781.
- Herrero, M., V. De Lorenzo, and K. N. Timmis. 1990. Transposon vectors containing non-antibiotic resistance selection markers for cloning and stable chromosomal insertion of foreign genes in gram-negative bacteria. *J. Bacteriol.* **172**:6557–6567.
- Hjerde, E., et al. 2008. The genome sequence of the fish pathogen *Aliivibrio salmonicida* strain LF11238 shows extensive evidence of gene decay. *BMC Genomics* **9**:616.
- Jones, B. W., and M. K. Nishiguchi. 2004. Counterillumination in the Hawaiian bobtail squid, *Euprymna scolopes* Berry (Mollusca: Cephalopoda). *Mar. Biol.* **144**:1151–1155.
- Kaplan, H. B., and E. P. Greenberg. 1985. Diffusion of autoinducer is involved in regulation of the *Vibrio fischeri* luminescence system. *J. Bacteriol.* **163**:1210–1214.
- Larkin, M. A., et al. 2007. Clustal W and Clustal X version 2.0. *Bioinformatics* **23**:2947–2948.
- Lee, K.-H. 1994. Ecology of *Vibrio fischeri*, the light organ symbiont of the Hawaiian sepiolid squid *Euprymna scolopes*. Ph.D. thesis. University of Southern California, Los Angeles, CA.
- Lee, K.-H., and E. G. Ruby. 1994. Competition between *Vibrio fischeri* strains during initiation and maintenance of a light organ symbiosis. *J. Bacteriol.* **176**:1985–1991.
- Lee, K.-H., and E. G. Ruby. 1992. Detection of the light organ symbiont, *Vibrio fischeri*, in Hawaiian seawater using *lux* gene probes. *Appl. Environ. Microbiol.* **58**:942–947.
- Librado, P., and J. Rozas. 2009. DnaSP v5: a software for comprehensive analysis of DNA polymorphism data. *Bioinformatics* **25**:1451–1452.
- Lupp, C., and E. G. Ruby. 2004. *Vibrio fischeri* LuxS and AinS: comparative study of two signal synthases. *J. Bacteriol.* **186**:3873–3881.
- Lupp, C., and E. G. Ruby. 2005. *Vibrio fischeri* uses two quorum-sensing systems for the regulation of early and late colonization factors. *J. Bacteriol.* **187**:3620–3629.
- Lupp, C., M. Urbanowski, E. P. Greenberg, and E. G. Ruby. 2003. The *Vibrio fischeri* quorum-sensing systems *ain* and *lux* sequentially induce luminescence gene expression and are important for persistence in the squid host. *Mol. Microbiol.* **50**:319–331.
- Mandel, M. J., E. V. Stabb, and E. G. Ruby. 2008. Comparative genomics-based investigation of resequencing targets in *Vibrio fischeri*: focus on point miscalls and artefactual expansions. *BMC Genomics* **9**:138.
- Mandel, M. J., M. S. Wollenberg, E. V. Stabb, K. L. Visick, and E. G. Ruby. 2009. A single regulatory gene is sufficient to alter bacterial host range. *Nature* **458**:215–218.
- Mayor, C., et al. 2000. VISTA: visualizing global DNA sequence alignments of arbitrary length. *Bioinformatics* **16**:1046–1047.
- Meighen, E. A. 1994. Genetics of bacterial bioluminescence. *Annu. Rev. Genet.* **28**:117–139.
- Miller, J. H. 1992. A short course in bacterial genetics. Cold Spring Harbor Laboratory Press, Cold Spring Harbor, NY.
- Miyashiro, T., M. S. Wollenberg, X. Cao, D. Oehlert, and E. G. Ruby. 2010. A single *qrr* gene is necessary and sufficient for LuxO-mediated regulation in *Vibrio fischeri*. *Mol. Microbiol.* **77**:1556–1567.
- Morrison, D. A. 2007. Increasing the efficiency of searches for the maximum likelihood tree in a phylogenetic analysis of up to 150 nucleotide sequences. *Syst. Biol.* **56**:988–1010.

45. Neelson, K. H. 1977. Autoinduction of bacterial luciferase. Occurrence, mechanism and significance. *Arch. Microbiol.* **112**:73–79.
46. Neelson, K. H., and J. W. Hastings. 1979. Bacterial bioluminescence: its control and ecological significance. *Microbiol. Rev.* **43**:496–518.
47. Nishiguchi, M. K. 2002. Host-symbiont recognition in the environmentally transmitted sepiolid squid-*Vibrio* mutualism. *Microb. Ecol.* **44**:10–18.
48. Nishiguchi, M. K., E. G. Ruby, and M. J. McFall-Ngai. 1998. Competitive dominance among strains of luminous bacteria provides an unusual form of evidence for parallel evolution in Sepiolid squid-*Vibrio* symbioses. *Appl. Environ. Microbiol.* **64**:3209–3213.
49. O'Grady, E. A., and C. F. Wimpee. 2008. Mutations in the *lux* operon of natural dark mutants in the genus *Vibrio*. *Appl. Environ. Microbiol.* **74**:61–66.
50. Pompeani, A. J., et al. 2008. The *Vibrio harveyi* master quorum-sensing regulator, LuxR, a TetR-type protein is both an activator and a repressor: DNA recognition and binding specificity at target promoters. *Mol. Microbiol.* **70**:76–88.
51. Posada, D., and T. R. Buckley. 2004. Model selection and model averaging in phylogenetics: advantages of Akaike information criterion and Bayesian approaches over likelihood ratio tests. *Syst. Biol.* **53**:793–808.
52. Pybus, O. G., and B. Shapiro. 2009. Natural selection and adaptation of molecular sequences, p. 413–415. In P. Lemey, M. Salemi, and A.-M. Vandamme (ed.), *A phylogenetic handbook: a practical approach to phylogenetic analysis and hypothesis testing*, 2nd ed. Cambridge University Press, Cambridge, United Kingdom.
53. Ronquist, F., and J. P. Huelsenbeck. 2003. MrBayes 3: Bayesian phylogenetic inference under mixed models. *Bioinformatics* **19**:1572–1574.
54. Ronquist, F., P. van der Mark, and J. P. Huelsenbeck. 2009. Bayesian phylogenetic analysis using MrBayes, p. 210–266. In P. Lemey, M. Salemi, and A.-M. Vandamme (ed.), *The phylogenetic handbook: a practical approach to phylogenetic analysis and hypothesis testing*, 2nd ed. Cambridge University Press, Cambridge, United Kingdom.
55. Ruby, E. G. 1996. Lessons from a cooperative bacterial-animal association: the *Vibrio fischeri*-*Euprymna scolopes* light organ symbiosis. *Annu. Rev. Microbiol.* **50**:591–624.
56. Ruby, E. G., and K.-H. Lee. 1998. The *Vibrio fischeri*-*Euprymna scolopes* light organ association: current ecological paradigms. *Appl. Environ. Microbiol.* **64**:805–812.
57. Ruby, E. G., and K. H. Neelson. 1976. Symbiotic association of *Photobacterium fischeri* with the marine luminous fish *Monocentris japonica*: a model of symbiosis based on bacterial studies. *Biol. Bull.* **151**:574–586.
58. Ruby, E. G., et al. 2005. Complete genome sequence of *Vibrio fischeri*: a symbiotic bacterium with pathogenic congeners. *Proc. Natl. Acad. Sci. U. S. A.* **102**:3004–3009.
59. Schuster, B. M., L. A. Perry, V. S. Cooper, and C. A. Whistler. 2010. Breaking the language barrier: experimental evolution of non-native *Vibrio fischeri* in squid tailors luminescence to the host. *Symbiosis* **51**:85–96.
60. Septer, A. N., J. L. Bose, A. K. Dunn, and E. V. Stabb. 2010. FNR-mediated regulation of bioluminescence and anaerobic respiration in the light-organ symbiont *Vibrio fischeri*. *FEMS Microbiol. Lett.* **306**:72–81.
61. Shadel, G. S., J. H. Devine, and T. O. Baldwin. 1990. Control of the *lux* regulon of *Vibrio fischeri*. *J. Biolumin. Chemilumin.* **5**:99–106.
62. Stabb, E. V. 2005. Shedding light on the bioluminescence “paradox.” *ASM News* **71**:223–229.
63. Stabb, E. V. 2006. The *Vibrio fischeri*-*Euprymna scolopes* light organ symbiosis, p. 204–218. In F. L. Thompson, B. Austin, and J. Swings (ed.), *The biology of vibrios*. ASM Press, Washington, DC.
64. Stabb, E. V., M. S. Butler, and D. M. Adin. 2004. Correlation between osmolarity and luminescence of symbiotic *Vibrio fischeri* strain ES114. *J. Bacteriol.* **186**:2906–2908.
65. Stabb, E. V., and D. S. Millikan. 2009. Is the *Vibrio fischeri*-*Euprymna scolopes* symbiosis a defensive mutualism?, p. 85–98. In J. F. White, Jr., and M. S. Torres (ed.), *Defensive mutualism in microbial symbiosis*. Taylor and Francis, Boca Raton, FL.
66. Stabb, E. V., K. A. Reich, and E. G. Ruby. 2001. *Vibrio fischeri* genes *hvnA* and *hvnB* encode secreted NAD⁺-glycohydrolases. *J. Bacteriol.* **183**:309–317.
67. Stabb, E. V., and E. G. Ruby. 2002. RP4-based plasmids for conjugation between *Escherichia coli* and members of the *Vibrionaceae*. *Methods Enzymol.* **358**:413–426.
68. Stabb, E. V., A. Schaefer, J. L. Bose, and E. G. Ruby. 2008. Quorum signaling and symbiosis in the marine luminous bacterium *Vibrio fischeri*, p. 233–250. In S. C. Winans and B. L. Bassler (ed.), *Chemical communication among microbes*. ASM Press, Washington, DC.
69. Swartzman, E., and E. A. Meighen. 1993. Purification and characterization of a poly(dA-dT) *lux*-specific DNA-binding protein from *Vibrio harveyi* and identification as LuxR. *J. Biol. Chem.* **268**:16706–16716.
70. Swofford, D. L. 2003. PAUP*: phylogenetic analysis using parsimony (*and other methods). Sinauer Associates, Sunderland, MA.
71. Tajima, F. 1989. Statistical method for testing the neutral mutation hypothesis by DNA polymorphism. *Genetics* **123**:585–595.
72. Urbanowski, M. L., C. P. Lostroh, and E. P. Greenberg. 2004. Reversible acyl-homoserine lactone binding to purified *Vibrio fischeri* LuxR protein. *J. Bacteriol.* **186**:631–637.
73. Visick, K. L., J. Foster, J. Doino, M. McFall-Ngai, and E. G. Ruby. 2000. *Vibrio fischeri lux* genes play an important role in colonization and development of the host light organ. *J. Bacteriol.* **182**:4578–4586.